



Connecting Instruction

To realize remote control and centralized control function of "C" series light commercial models

To add remote and centralized control function, we developed an auxiliary PCB, as shown below:
(for the indoor units with 5 pin wired controller)

CSP-CENTR-PCB

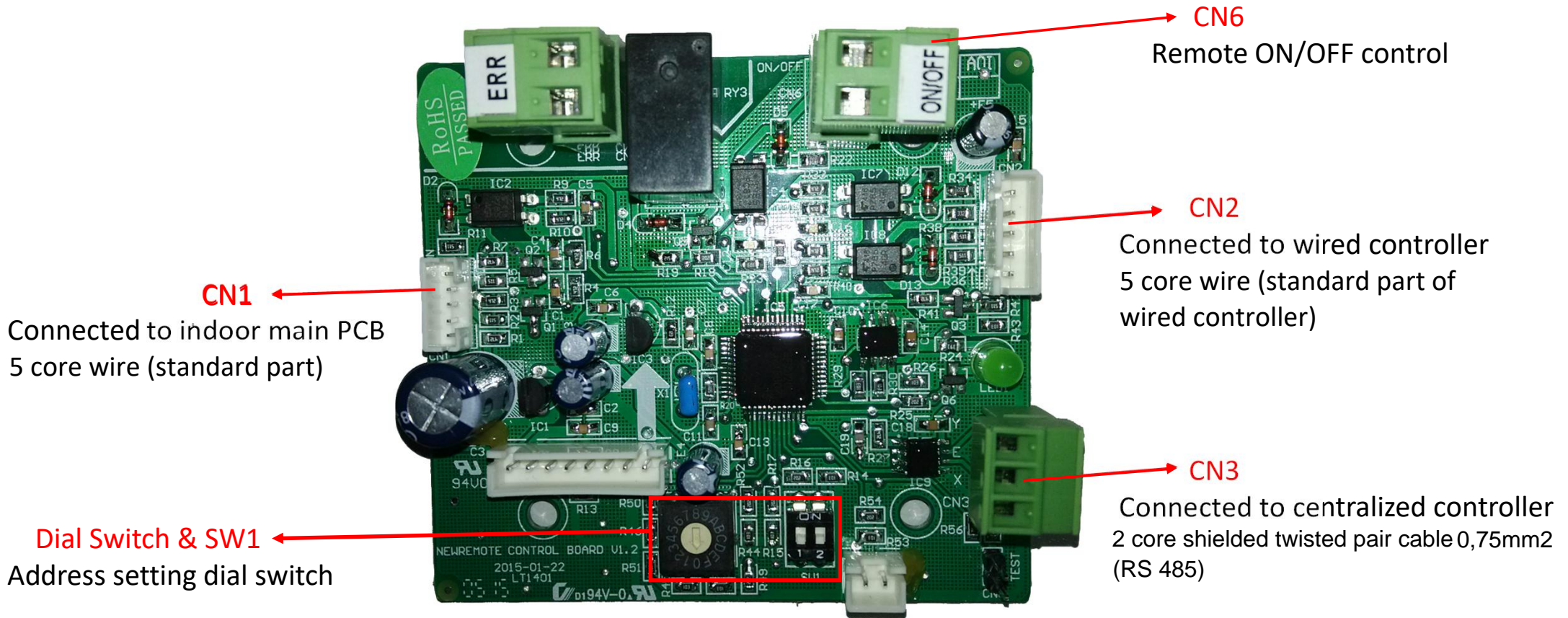

The wiring diagram :

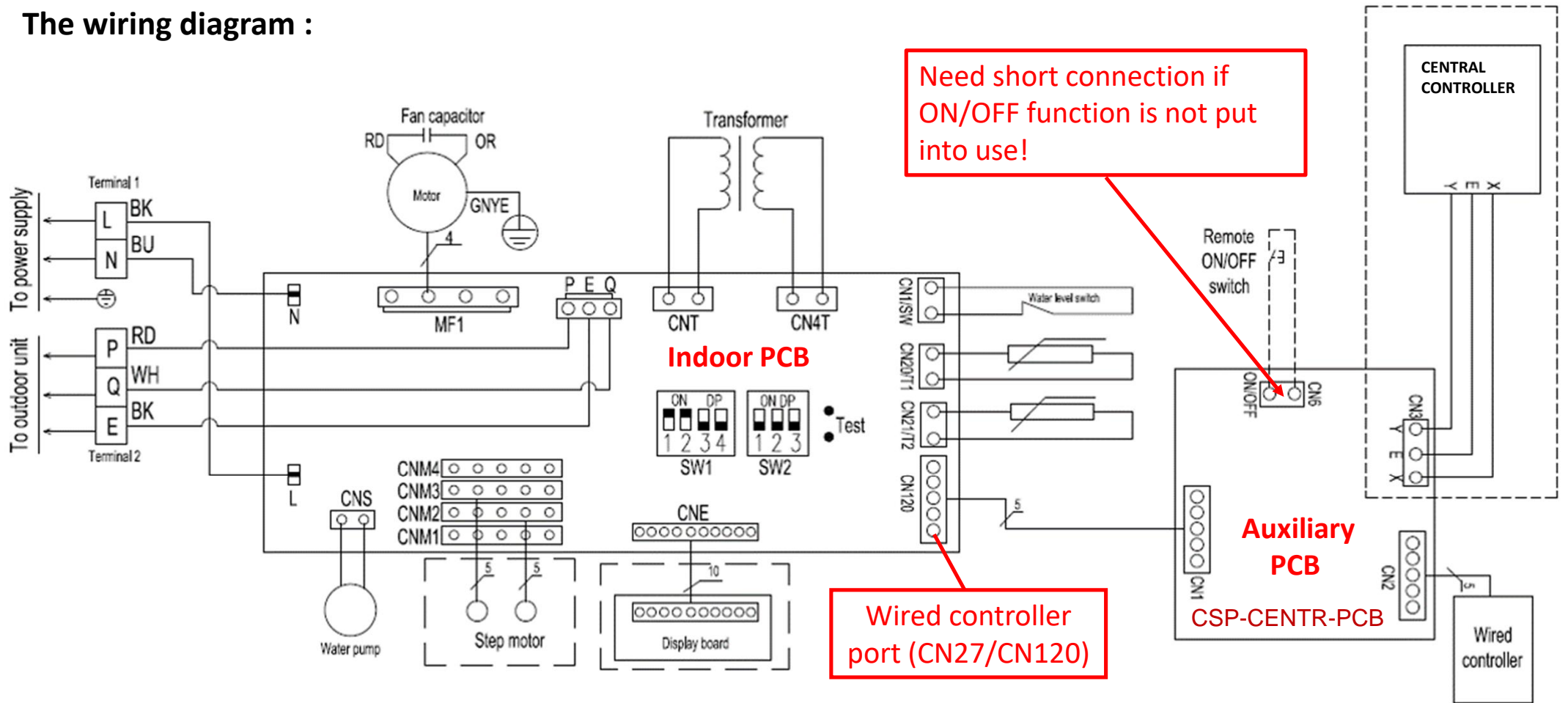

XYE port is used to connect to Modbus, simple centralized controller, Smart box.

Connect with centralized controller

All indoor units addresses should be different.

The max. quantity of indoor units is 64.

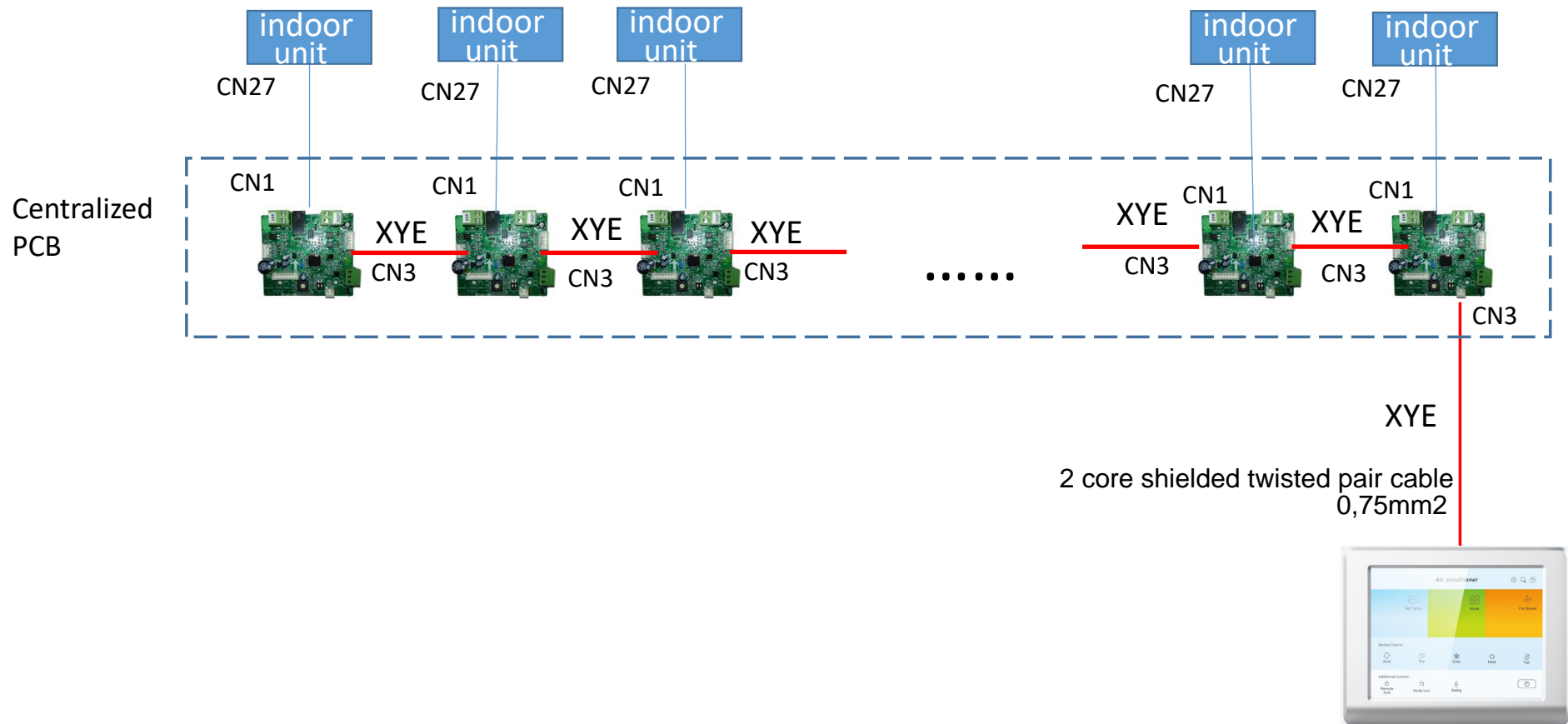

Connect with modbus board

All indoor units addresses should be different.

The max. quantity of indoor units is 64.

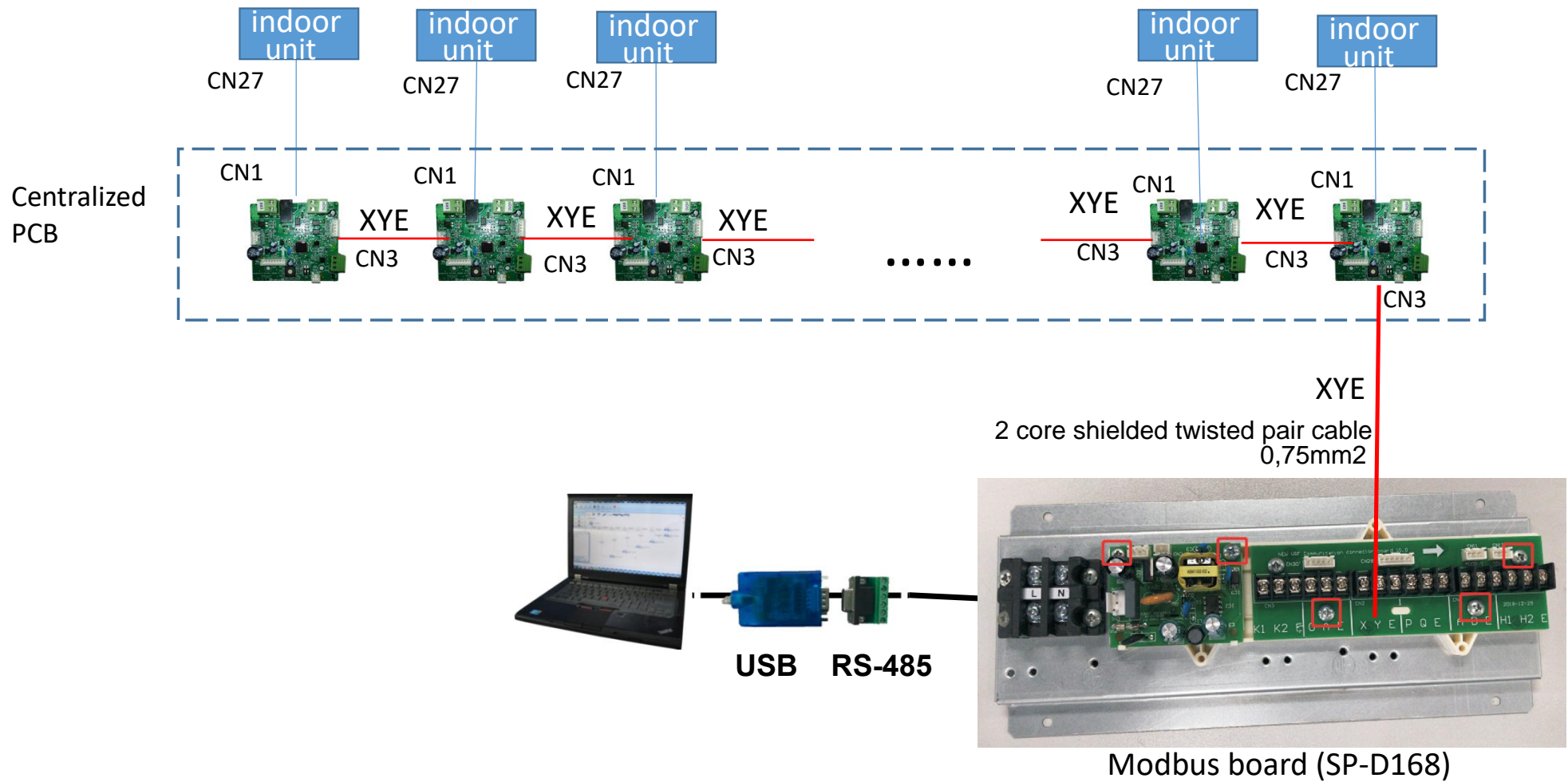

Connection instruction:

Firstly use the wire, which used to connect the wired controller and indoor main PCB, to connect the auxiliary PCB and indoor main PCB by CN1 and CN120. The wired controller can be connected to the auxiliary PCB by CN2.

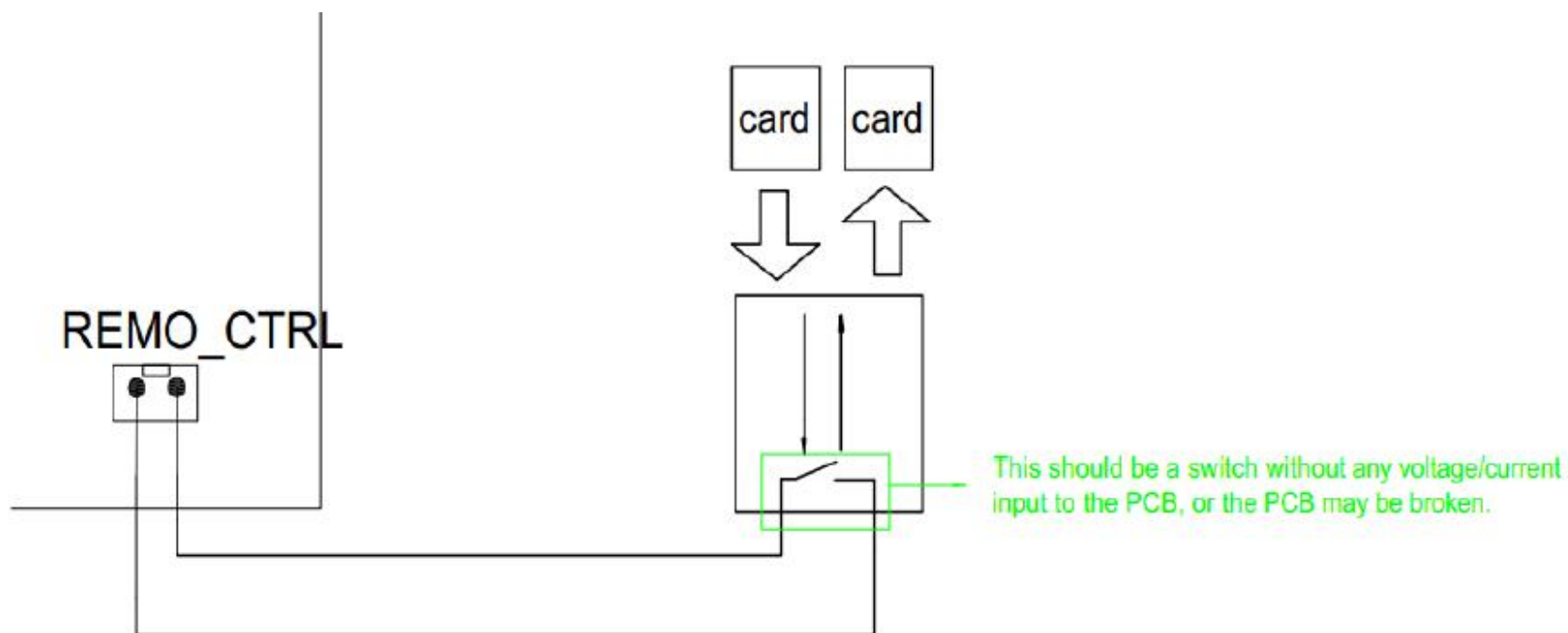

1. Remote ON/OFF control function

Realize remote control function, can be applied to hotel card etc.



2. Centralized control function

Connect the centralized controller to CN3 of the auxiliary PCB, and set the indoor unit address manually by address setting dial switch. The setting rule is shown as below:

Address parameter	SW1 	Dial Switch 
0 ~ 15	1:OFF 2:OFF	Address = Dial code
16 ~ 31	1:OFF 2:ON	Address = 16 + Dial code
32 ~ 47	1:ON 2:OFF	Address = 32 + Dial code
48 ~ 63	1:ON 2:ON	Address = 48 + Dial code